

FORCE

RESCUE EQUIPMENT

FORCE Rescue Equipment was introduced in 1968 and is today in service in some 30 countries in tens of thousands of units. In many countries it is specified as **standard equipment** for civil and military rescue work - for ambulance, police, road patrols, rescue helicopters, sea- and airrescue.

The time available for rescue work is nearly always very short. When **FORCE** was developed, the requirement was therefore a piece of equipment which was easy to handle, versatile, durable, with a large capacity and which did not require time-consuming tool changes. The result was a manual rescue equipment specially designed for the first life-saving effort - to free trapped and jammed persons.

The tool functions that are needed, to make holes, cut, bend, lift, pull, support and so on, have been combined into one unit, which is easy to handle and easy to learn to use.

FORCE is a complement to the rescuer's own muscular power and has sometimes been called the third arm - the rescue arm. The rescuer is ready in a few seconds and with the help **FORCE** of his capacity is increased when time is short, under difficult and cramped conditions.

This manual presents **FORCE** Rescue Equipment with the help of abundant picture material.

It is impossible to give a direct instruction about how individual rescue work should be carried out, but the chapter dealing with *utilization of the tool* and *training - forced car entries* show the versatility of the equipment. The work technique with **FORCE** is the same irrespective of the type of rescue work: traffic-, air-, train- and sea incidents, explosions, fires e t c. Through practical training one learns to know the equipment's versatility and capacity and your own ability to utilize **FORCE**, when advisable. It always depends on the individual person, how successful the outcome will be.





FORCE Rescue Equipment consists of:
 Rescue Tool (2 parts, axe- and clawpart)
 Rescue and transport strap
 Holder/Stand

Rescue Tool

Type:	FORCE
Weight:	4.2 kg (axe 2.6 - claw 1.6)
Length retracted:	565 mm
extended:	840 mm
Material:	Axe, claw - Steel (special alloy, hardened) Handle - EPDM-rubber on pipe of special steel Latch mechanism - Stainless steel



Rescue and transport strap

Weight:	0.85 kg
Length:	2500 mm
Material:	Nylon
Tensile strength:	Strap - 30 kN (3000 kp) D-ring, hook, buckle - 25 kN (2500 kp)



Holder/Stand

Weight:	0.45 kg
Dimensions:	90 x 453 mm, height 53 mm
Material:	Aluminium, 3 mm
Shock resistance:	With installed equipment - 40 g without damage



Strap

1. Undo flap.

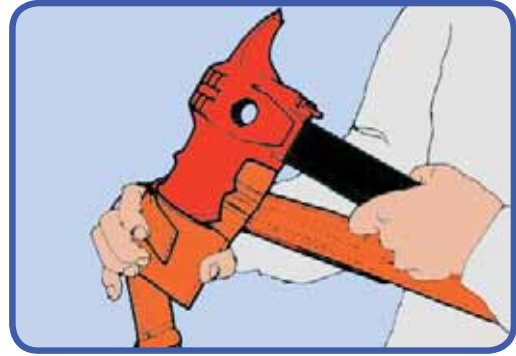

2. Remove cover.



3. Remove cover.



4. Fourreau.

Rescue Tool

5. Unlatch locking device.



6. Pull out claw part completely.



7. Push back to red line. Twist half a turn.

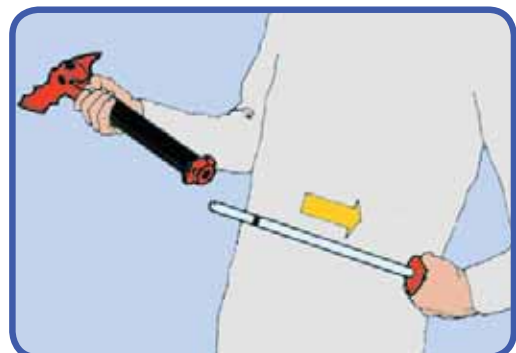

8. Pull out and free claw part.

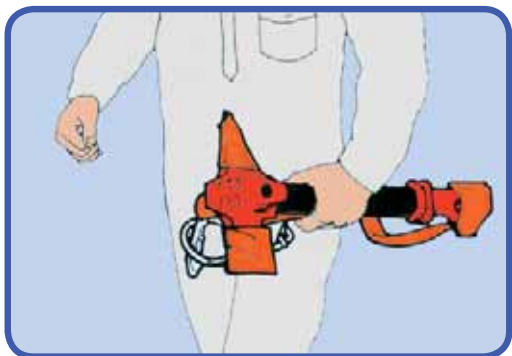

1. One hand free.



2. One hand free.



3. Both hands free.



4. Both hands free.



5. From back to chest position.



6. Belt used as safety belt.



7. Claw part attached to hook and D-ring.

Rescue work is often risky, carried out under cramped and difficult conditions. It puts great demand upon protection and safety. Great care has been devoted to these questions in design, choice of material and testing.

The tool is manufactured of hardened special steel which is hard but still so tough that it will not shatter during rough handling even in severe cold.

The strong handle made of steel-pipe is equipped with an anatomically shaped rubber handle which is shock absorbing.



1.



2. Guards against slipping hands.
Guided pumping function.



3. Latch stops claw part from accidentally gliding out.



4.

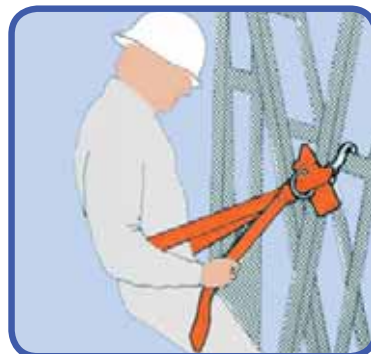

5.



6.

Strap has a safety latch with one-hand quick-release.

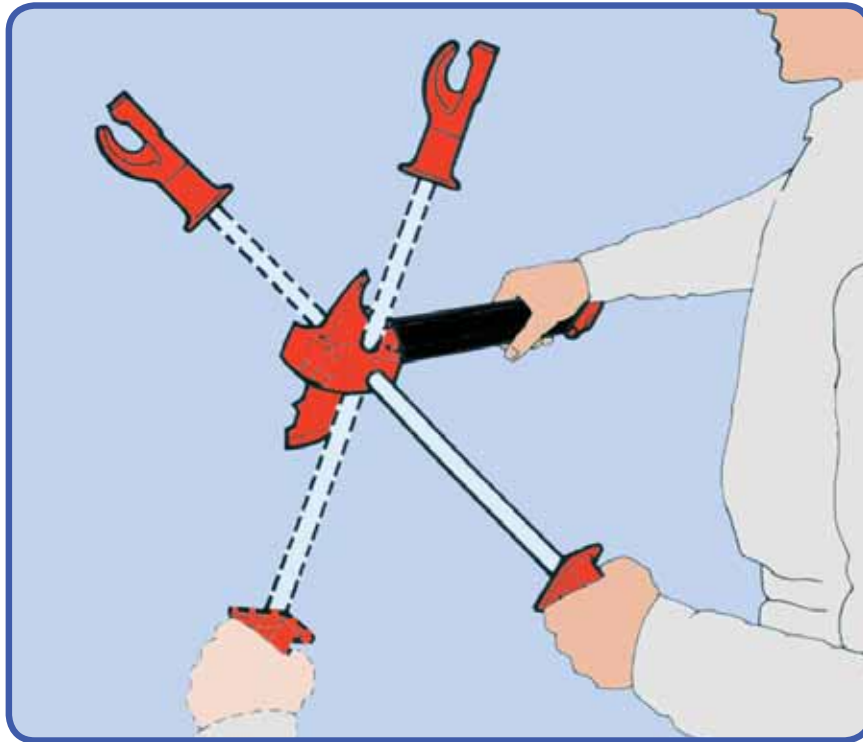

1. Two-hand grip in four different positions. Gives good guidance and accessibility. Less risk of slipping. Easily broken loose, if it gets stuck.

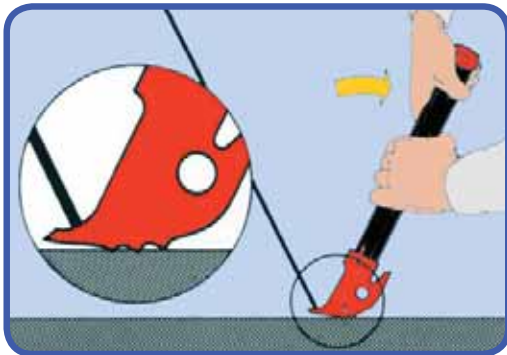

2. Large supporting surface with grip-teeth. Point of support moves resulting in even lift.

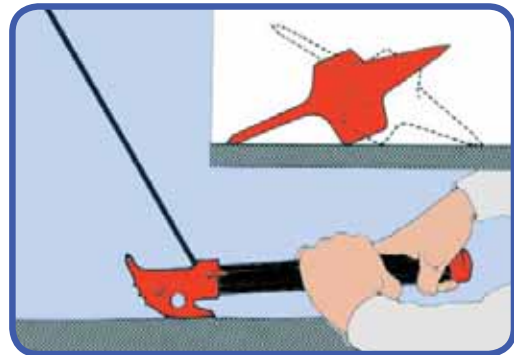

3. Axe blade and pick stop the tool from tipping over.

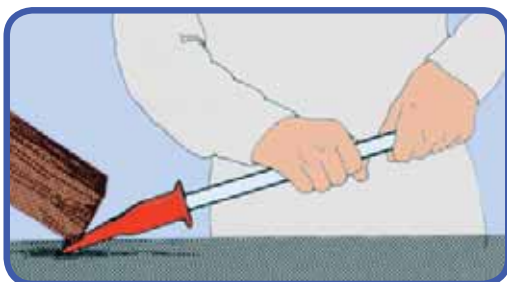

4.



5. Collar serves to stop slipping and grips in the ground.

Maintenance - Edges

Axe-, chisel- and pick edges are chise-honed, i.e. the forward part of the cutting edge is equipped with a thin and blunted edge that gives great strength.

Sharpening of edges can be done with a grinding belt or with a fine-toothed file. Use relatively coarse belt - grit size 50-80 - to prevent the hardness being reduced by heat. Maximum temperature 200°C.

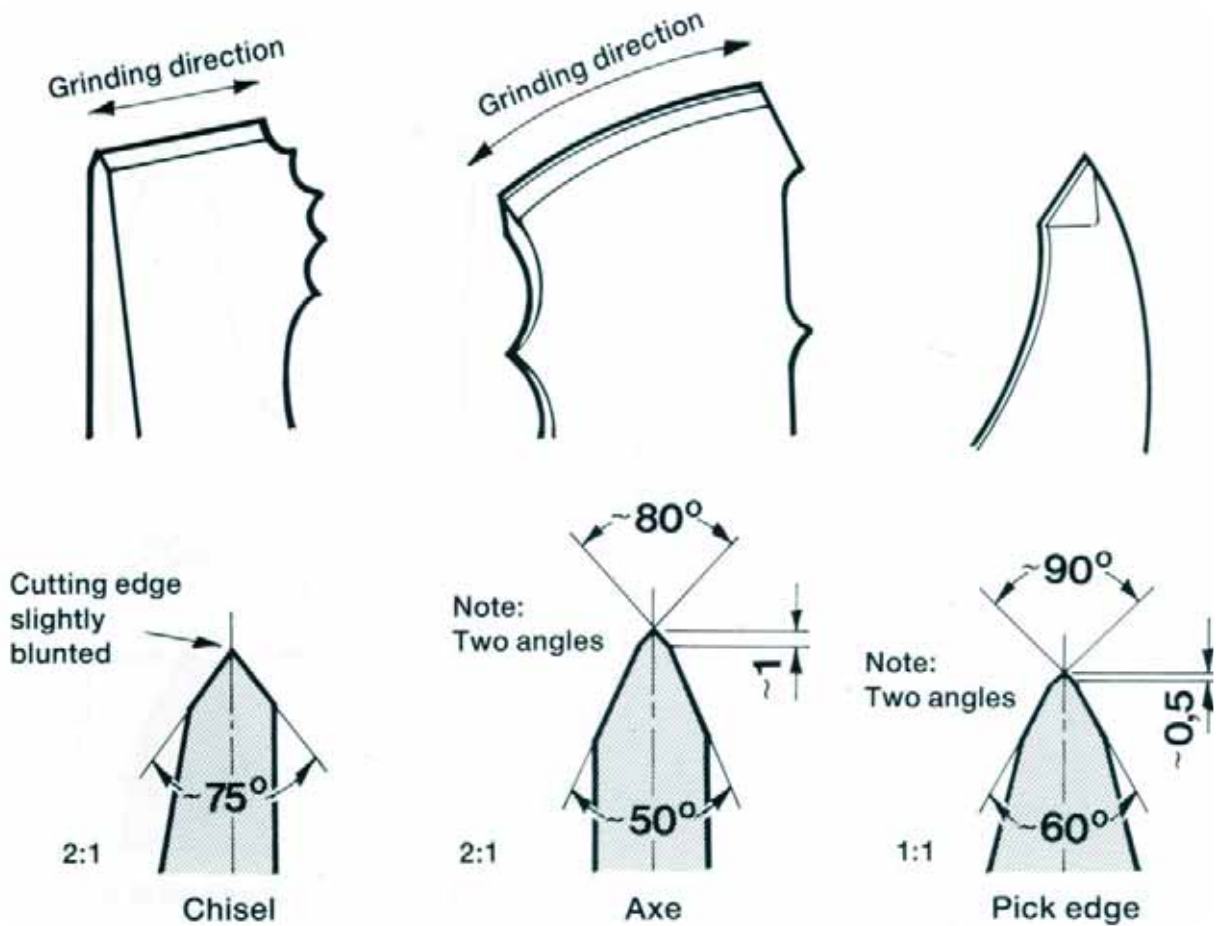

Rubber handle

A clean handle gives a good grip and is clearly visible. Clean with household detergent, petrol, acetone or any similar cleaner.

Latch mechanism

The latch, which is made of stainless steel, has solid lubricant on bearing surfaces and need not be lubricated. The thread of the latch pin is locked with locking fluid. At reassembly, locking can be carried out with locking fluid, plastic glue or similar.

Packing - Preparation prior to stand-by

If the strap is adjusted to its correct length, for example for back-carrying before the equipment is attached to its holder - time is saved at alarm.

Guarantee

For material and fabrication faults, there is one year guarantee from the date of delivery according to current rules for mechanical products. We will take no responsibility and give no compensation for direct or indirect damage to property or injury to person that might occur in connection with the use of FORCE Rescue Equipment.



1. Windows.



2. Wire reinforced windows.



3. Plexi- and safety glass, car windows, aircraft-canopies and windows.



4. Tarpaulins, tents etc. - use axe-pick.



5. Punch hole.



6. Car roof, etc. - slanting short hits.

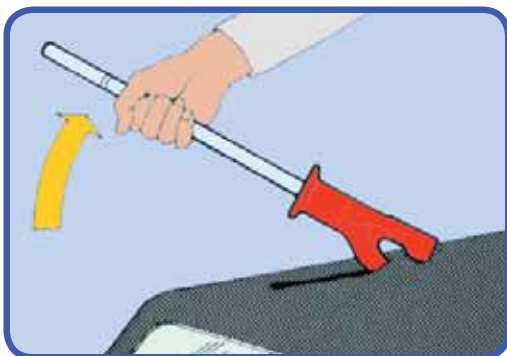

7. Rapid cutting in thin sheet metal.

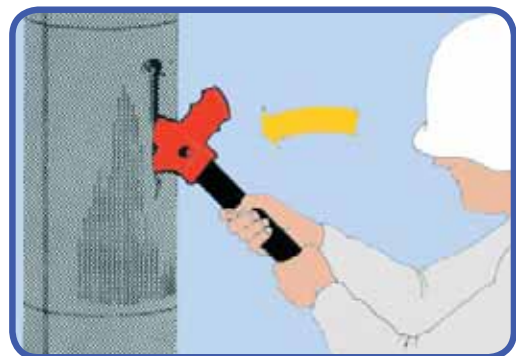

8. Thin isolating sheet metal - use axe-pick.



1. Hack off.

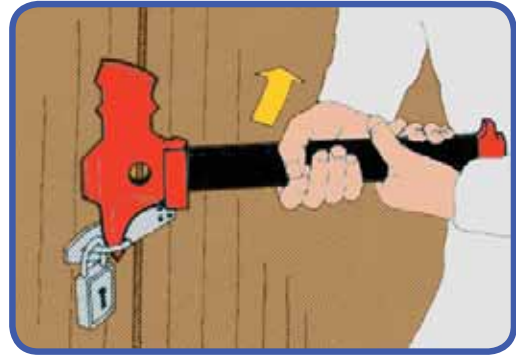

2. Pull out.



3. Pull out.

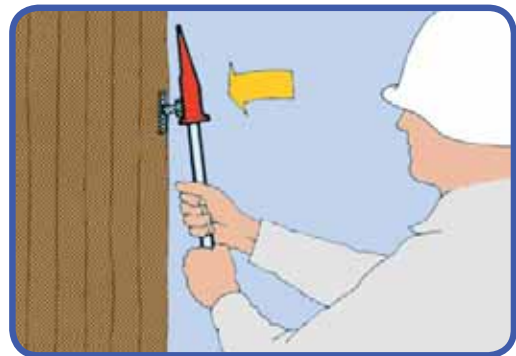

4. Knock out - nail together.



5. Wire, ropes, cables etc. - short hits - support rod against arm.

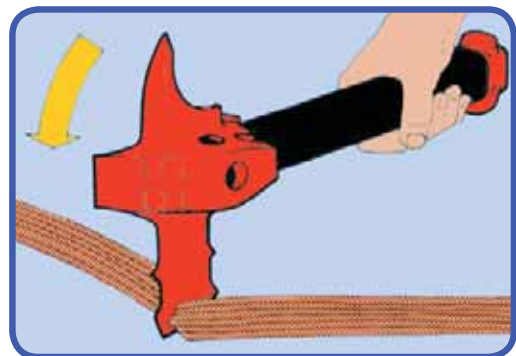

6. Wire, ropes, tubing etc. - cutting against hard support.

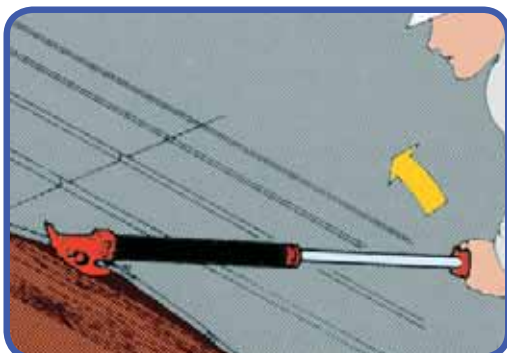

7. Breaking up roof, sheet metal.

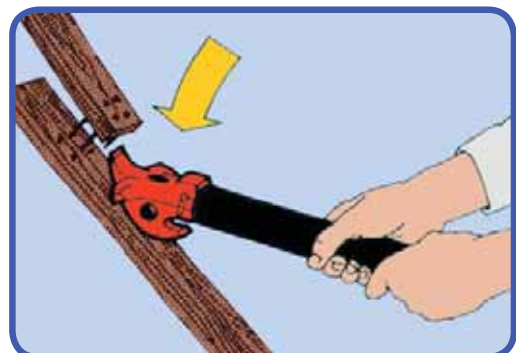

8. Hitting with the rounded part - sledgehammer action.

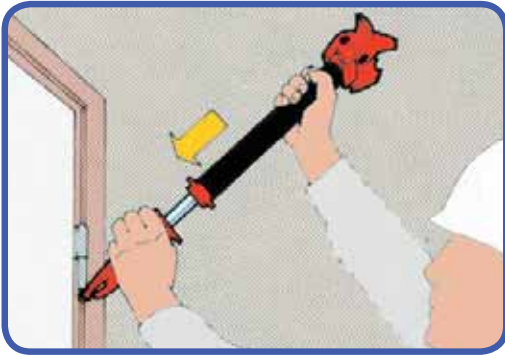

1. Pushing out pins and bolts.



2. Cutting off rivet- and boltheads.

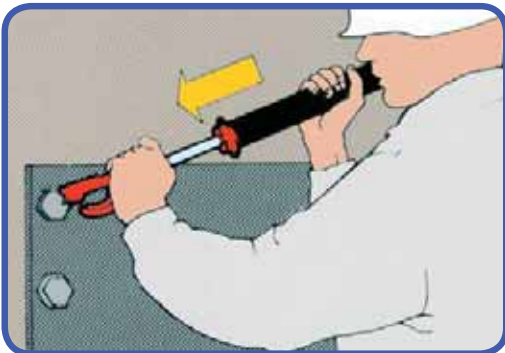

3. Undoing and unscrewing bolts and screws.



4. Pushing in pins, dowels etc.

Sparkfree opening up of sheet metal

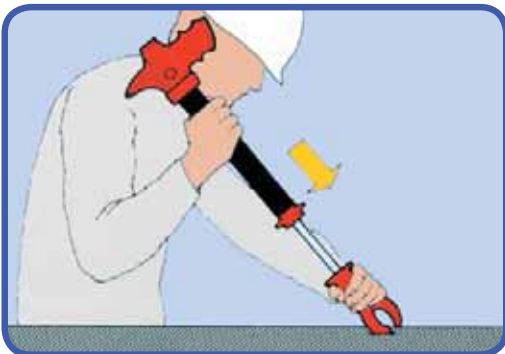

5. Punch hole with chisel.

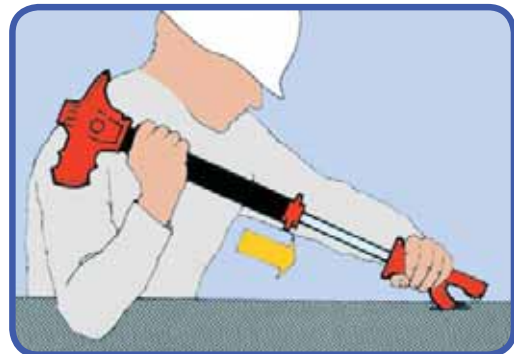

6. Insert claw-edge.

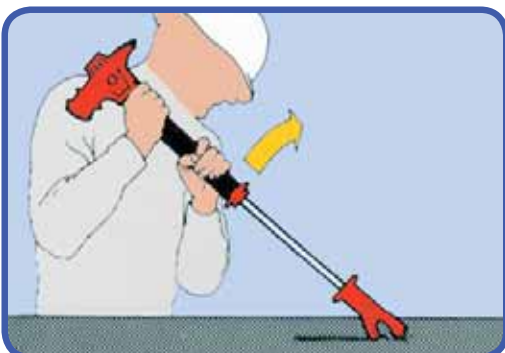

7. Long leverage in thick sheet metal (2-3 mm).



8. Only claw part in thin metal - car roofs, driver cabins etc.

Forcing wooden floors, boxes, walls etc.



1. Pierce floor with pumping motion.

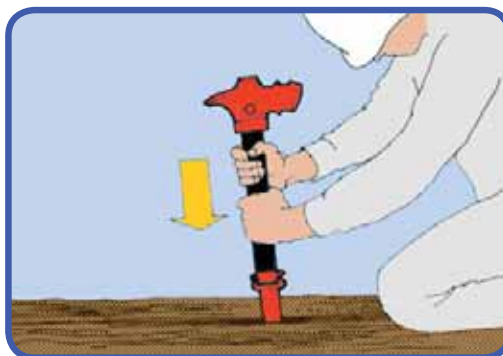

2.



3. Break - long leverage.



4. Break - two-hand grip.



5. Split board - use pick.



6.



7. Break up - two-hand grip.



8.

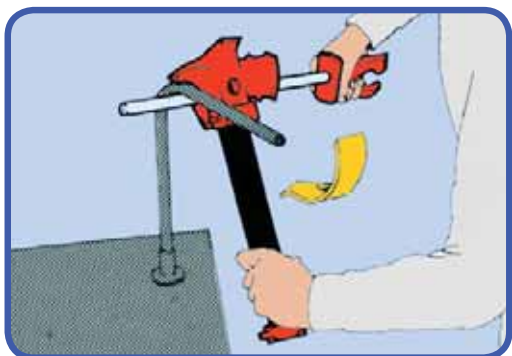

1. Bending pipes - pick part.



2. Bending flat iron - axe blade.



3. Flattening pipe - stopping liquid flow.

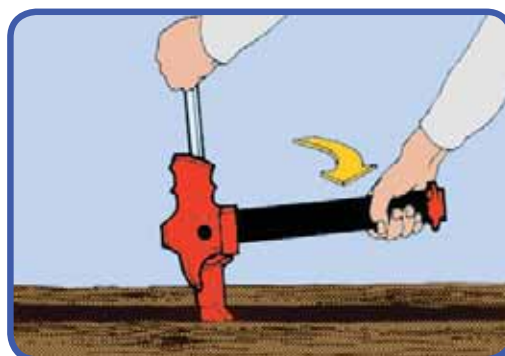

4. Leverage. Drive in chisel with pumping motion - turn with the axe handle.



5. Leverage.



6. Scraping off earth, ice etc.



1.



2.

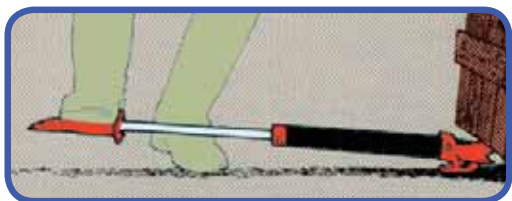

3.



4.

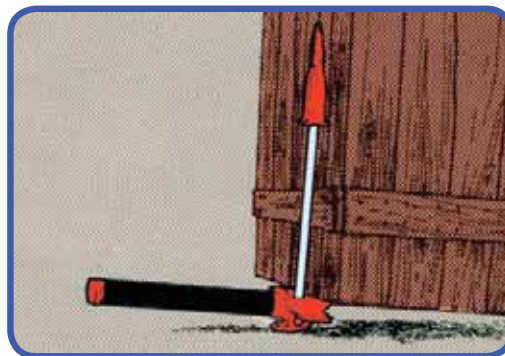

5.



6.

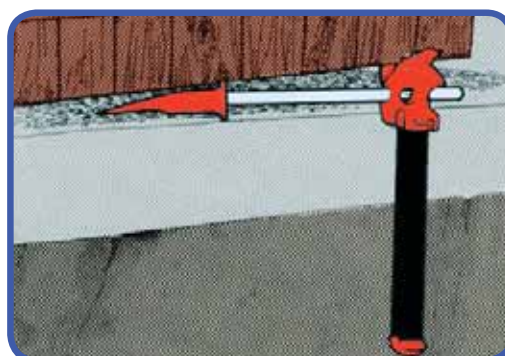

7.

Winching - rope tightening.

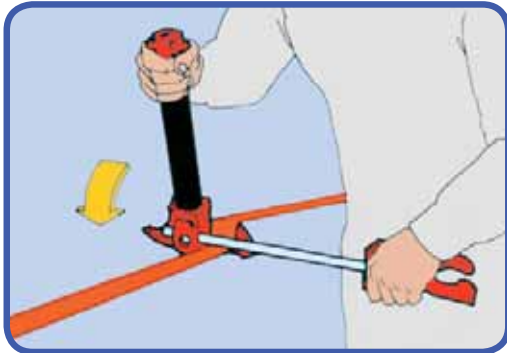

1. Strap between rod and axe blade.

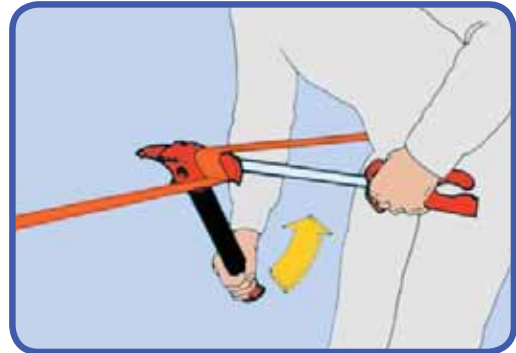

2. Pulling force 5-10 kN (500 - 1000 kp).

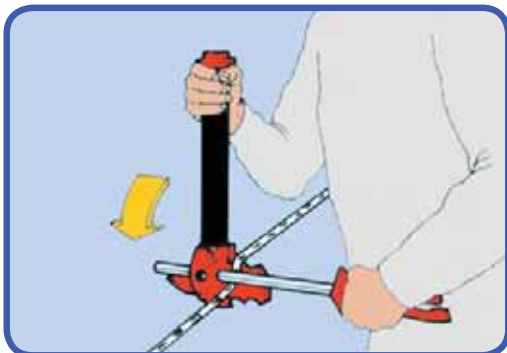

3. Rope between rod and axe blade.

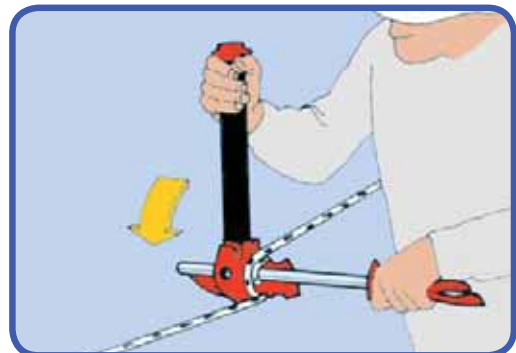

4.

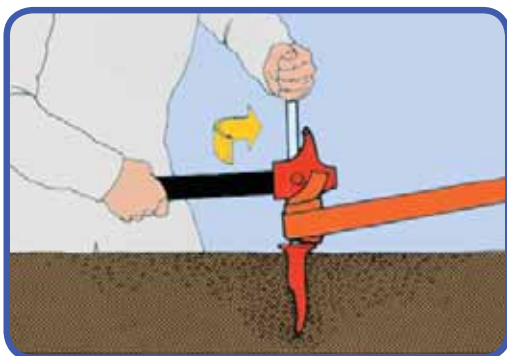

5. Claw part well secured.



6. Vertical winching.



7.



8. Moving sheet metal etc.



1. Lifting with legs - aid with hands.



2. Horizontal pull.



3. Leverage lift.

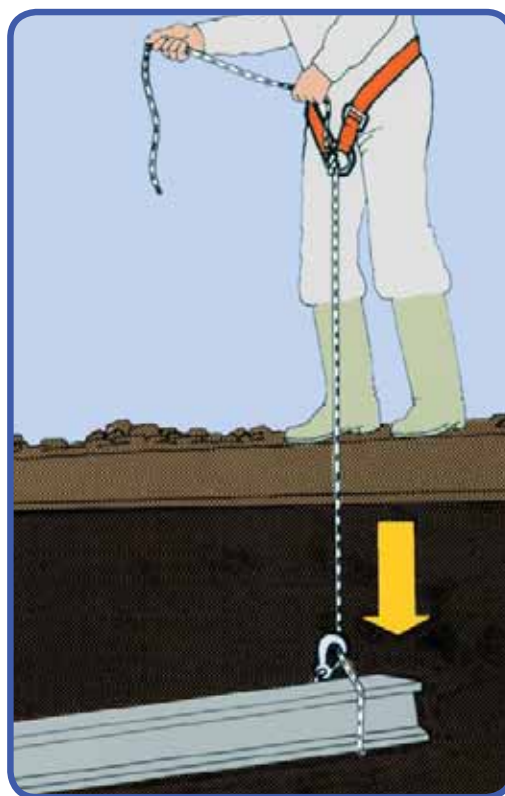

4. Lower with D-ring as winch brake.



1. Supporting - protection of injured.



2.

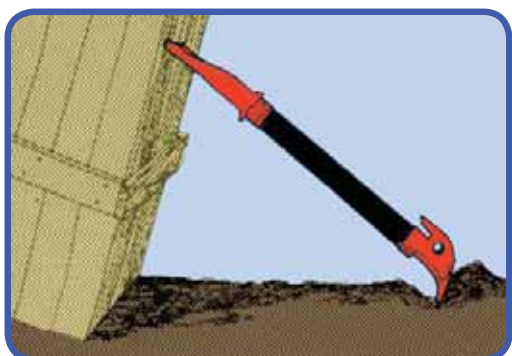

3.

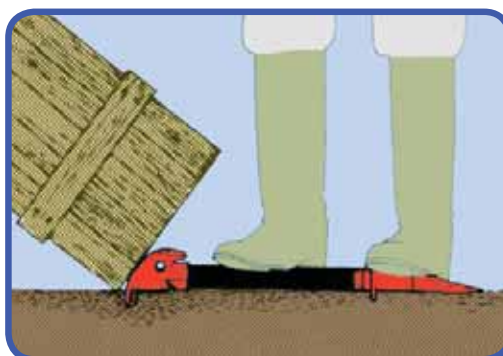

4.

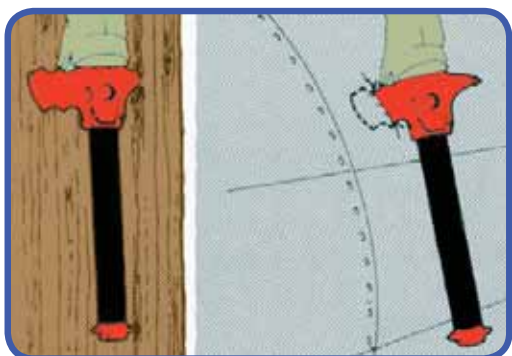

5. Emergency foot support.



6. Support for self-protection.

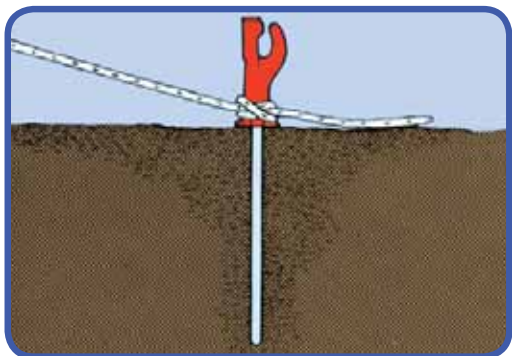

1. In firm earth.

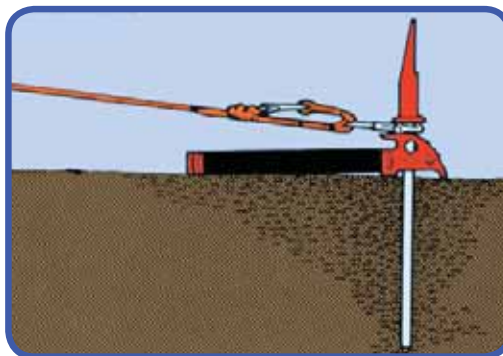

2. In soft earth.



3. Anchoring in rock - claw part well inserted.



4.

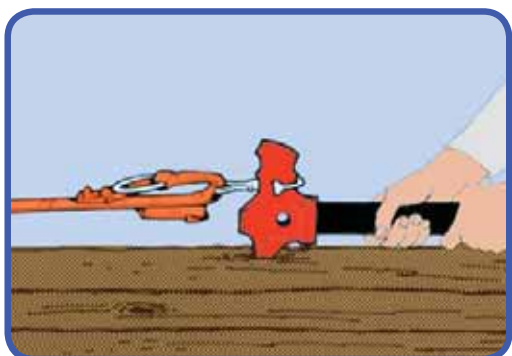

5. In wood etc.

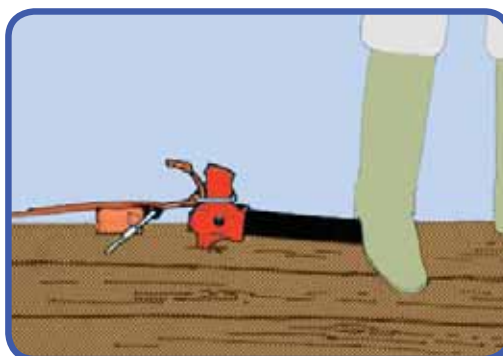

6. In wood etc.

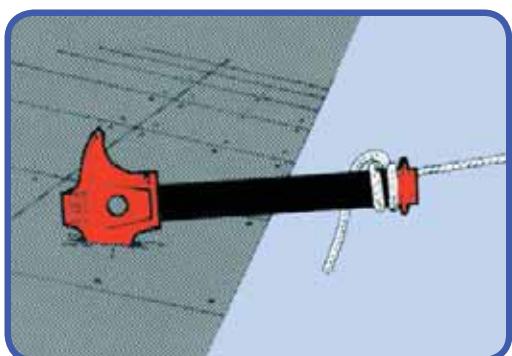

7. In sheet metal, wood etc.

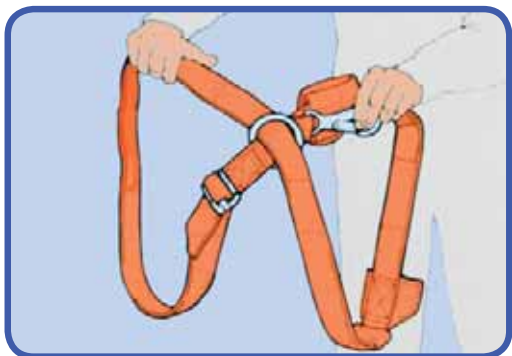

1. Rescue sling - arrangement for fig 2, 3 and 4.



2. Both hands free.



3. Transport of unconscious.



4. Lift with back support.

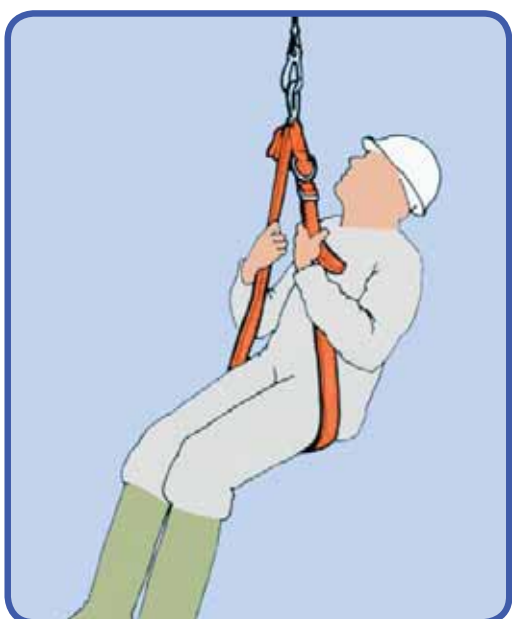

5. Seat lift.

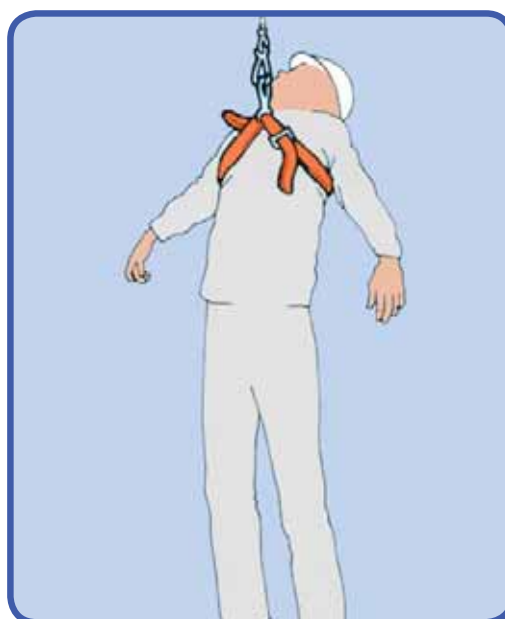

6. Chest lift - tighten belt well.



1. Weight on shoulders.



2. One hand free - D-ring in handle.



3. Pulling with belt - twisted belt gives head support.



4. Transport in low passages.

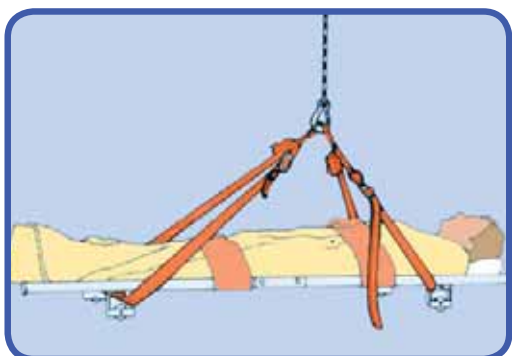

5. Arrangements with two belts. Stretcher level adjustable with belt length.

Always try first to open the door by hand with some strong pulls even if it is heavily deformed. Blockage is probably due to the door being compressed under tension - the door opening is smaller than the door.



1. Release tension by hitting. Use curved side of axe part.



2. Use full swing - hit hard.

Hard hitting:

Right hit - right hand far down on the handle - guide with left hand (fig. 2).

Left hit - reverse (fig. 3).



3. Hit on both sides of the lock.



4. Insert axe blade in gap.



5. Turn upwards. The door is lifted - structure is bent apart - opening of the door increases.



6. Open the door by turning the handle straight out - horizontally.



1. Loosen chrome strip with chisel or axe-pick.



2. Pull away chrome strip.



3. Loosen rubber insert with chisel.



4. Pull away rubber.



5. Remove windscreen with the breaking edge or with chisel.



6.

Cut the roof open



1. Make a hole with the pick.



2. Cut with claw part.



3. Cut with claw part.

Chopping the roof open



4. Chop close to the roof edge - slanting short hits.



5. Leave some material in the corners until last.



6. Fold the roof back.

First remove back and side windows



1. Perforate the lower part of the roof pillars with the pick.



2. Cut off the roof pillars.



3. Cut cables while holding them with claw apart.



4. Perforate both sides of the roof in the folding line.



5. Break the roof with a few strong blows.



6. Stamp on the roof if needed.



7. Fold the roof open.

Bending aside the steering wheel

Run the strap around the hips and attach the hook to the steering wheel.

Note: Strap should be low on the hip-bones.



1. Obtain pull by leaning body backwards.



2. Bend legs and tighten belt. Pull by straightening legs.



3. With two straps - double pull and good support.

Bending away foot pedals



4. Strap attached to the door using the door as leverage.



5. By pulling. Strap around hips.



1. Bend the mudguard away.



2. Cut the mudguard - use the pike.



3. Cut the mudguard - use the edge.



4. Cut the mudguard - use the claw part.



5. The wheel is free.

Supporting



1.



2.

Puncture



3. Puncture tyres with the pick - hit close to rim.